



ASF Mono & Twin Units

Automatic strap coil feed-up, changeover and strap tail removal

Increased productivity

Continuous strapping unit operation. No production stops to change strap coils with the twin model.

Very easy to use

Simple set-up. Production runs as strap coil changed. Auto strap thread-up and auto strap tail removal.

Improved safety

Twin safety zones, no need to access machine, auto strap feed to strapping head, reduces workload.

Solution flexibility

As a retrofit kit or with new machine. Easy integration, simple interface, adaptable to most customers needs.

ASF Mono & Twin

Automatic strap tail removal,
changeover and strap coil feed-up



ASF Technical Specifications

Feeder unit	Electric with automatic strap change-over on twin model
Cycle time	Mono: approx. 12 seconds to remove strap from machine Twin: approx. 25 seconds to remove strap-tail from machine, index to second strap supply and re-feed
Strap type	12 - 19 mm PET, others on request
Strap feeder tube	6 m standard from ASF to strap unit
Models	Mono version for single strap dispenser Twin version to serve two strap dispensers
Operation	Electric and pneumatic
Pneumatic connection	min 5 Bar
Air consumption	5 L / cycle
Electrical supply	380-480 V AC, 47-63 Hz + N+PE
Power consumption	0,25 kWh (mono) 0,4 kWh (twin)
Control voltage	24 V DC
Max. fuse	16 A
Throughput	Continuous as strapper does not stop for coil changes with ASF Twin and two dispensers
Unit weight	145 kg approx (mono), 270 kg approx (twin)
Strapping heads	Z20, AK200, others on request
Control panel	Manual controls on ASF, controlled through strapping machine controls
Colours	Machine Frame: Black Alu. RAL 9005 El. Cabinet: Light Grey RAL 7035 Moving Parts: Yellow RAL 1018

ASF Strap Specifications

Strap feed-up speed	3.1 m/sec
Strap type	PET Polyester
Strap width	12 - 19 mm
Strap thickness	0,7 mm to 1 mm

Standard Features

- Robust, small footprint design
- Automatic strap infeed and take-up
- Fully automatic strap changeover in twin model
- ASF controls integrated inside unit
- Can be delivered as retrofit kit to existing machines, with own controller
- Fast and easy installation onsite
- "Strap coil end" pre-warning alarm and coil tail removal
- Suitable for single or twin dispensers from 70 up to 300 kg PET coils

Versions

- Model Mono: needs a single strap dispenser serving the ASF with a fixed strap feed and removal tube to the strapping head.
- Model Twin: needs two dispensers serving the ASF with indexing strap feed and removal tube to the strapping head
- Optional delivery of updated unit safety guarding fences

Dimensions:

Drawing shows ASF Mono/Twin
All dimensions in mm

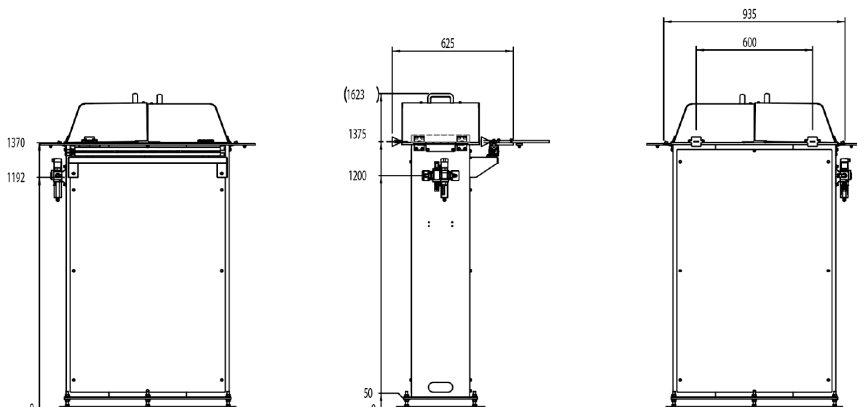

ASF Model Dimensions

Version	Height	Length	Width
Mono	1.620mm	625mm	485mm
Twin	1.620mm	625mm	935mm