

TECHNICAL DATA / GIROTEC II RDL 1800

Capacity:	15-25 pallets/hour (depending on goods wrapped)
Max wrapping height:	1850 mm
Rotation speed:	11 rpm
Power supply:	24V, charger 220-240V/50 Hz
Battery charging time:	~8 hours
Battery capacity:	up to 100 pallets
Overall dimensions	W/L/H 2050x2630x2160mm
Machine weight:	220 kg
Max pallet dimensions:	800x1200x1800mm (1000kg)

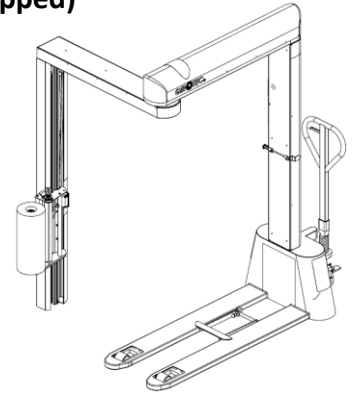

Allowed operating conditions:

Temperature +5C° +40C° at max relative humidity of 76%

Short description:

Machine is equipped with pallet truck. Machine and pallet can be easily moved around warehouse.

